

MANUAL CHANGES

MANUAL IDENTIFICATION

Model Number: 141T
 Date Printed: June 1976
 Part Number: 00141-90914

This supplement contains important information for correcting manual errors and for adapting the manual to instruments containing improvements made after the printing of the manual.

To use this supplement:

Make all ERRATA corrections.

Make all appropriate serial number related changes indicated in the tables below.

Serial Prefix or Number	Make Manual Changes	Serial Prefix or Number	Make Manual Changes
1850A	1		
2020A	1,2		
2101A	1,2,3		

▲ NEW ITEM

ERRATA

Paragraph 2-13,

Delete paragraph 2-13.

Paragraph 5-27. Intensity Limit Adjust,

Change Method B, step f to the following:

f. Set INTENSITY between 10 o'clock and 2 o'clock positions.

Table 6-2. Replaceable Parts,

Change: DS1 HP Part No. 1450-0566, LIGHT-IND WHT-TL .4 DIA SLDR-LUG-TERM, Mfr Code 91802, Mfr Part No. 2910S17.

Add: J9E1 through J9E6, HP Part No. 5021-0906, Qty 9, SLEEVE-RF PIN POSITIONING, Mfr Code 28480, Mfr Part No. 5021-0906.

Add: J11E2 through J11E4, HP Part No. 5021-0906, SLEEVE-RF PIN POSITIONING, Mfr Code 28480, Mfr Part No. 5021-0906.

Change: MP38, HP Part No. 0340-0858, INSULATOR-THRM-CNDCT, Mfr Code 86464, Mfr Part No. 7403-09ER-05.

Delete: MP58.

NOTE

Manual change supplements are revised as often as necessary to keep manuals as current and accurate as possible. Hewlett-Packard recommends that you periodically request the latest edition of this supplement. Free copies are available from all HP offices. When requesting copies quote the manual identification information from your supplement, or the model number and print date from the title page of the manual.

- Change: MP61, HP Part No. 00141-01210, Qty 2, CORNER BRACE, Mfr Code 28480, Mfr Part No. 00141-01210.
- Change: MP73, HP Part No. 00141-03101, Qty 1, PLUG-IN GUIDE, Mfr Code 28480, Mfr Part No. 00141-03101.
- Change: MP74, HP Part No. 00141-03102, Qty 1, RIGHT VERT GUIDE, Mfr Code 28480, Mfr Part No. 00141-03102.
- Change: MP75, HP Part No. 00141-03103, Qty 1, GUIDE SUPPORT, Mfr Code 28480, Mfr Part No. 00141-03103.
- Change: W1 (POWER CORD) HP and Mfr Part Nos. to 8120-1521.
- Change: A2C8, HP Part No. 0160-0301, CAPACITOR-FXD 0.012UF .200V, Mfr Code 06001, Mfr Part No. 608D1EH123PK201AX.
- Change: A2R44, HP Part No. 0698-3177, Qty 1, RESISTOR 20K 2% 1W MO TC=0+—200, Mfr Code 11502, Mfr Part No. RG-42-1-8-2002-G.
- Change: A2R46, HP Part No. 0757-0346, RESISTOR 10 1% .25W F TC=0+—100, Mfr Code 28480, Mfr Part No. 0757-0346.
- Change: A2R63, HP Part No. 2100-0569, RESISTOR-TRMR 1M 20% C TOP-ADJ 1 TRN, Mfr Code 73138, Mfr Part No. 72-116-0.
- Change: A2R66, HP Part No. 0699-0221, Qty 1, RESISTOR 33M 5% 1W C TC=0+—250, Mfr Code 28480, Mfr Part No. 0699-0221.
- Change: A2R65, HP Part No. 2100-3501, RESISTOR-TRMR 2M 20% C TOP-ADJ 1-TRN, Mfr Code 28480, Mfr Part No. 2100-3501.
- Change: A2R72, HP Part No. 2100-3214, RESISTOR-TRMR 100K 10% C TOP-ADJ 1-TRN, Mfr Code 28480, Mfr Part No. 2100-3501.
- Change: A5Q2, HP Part No. 1855-0027, TRANSISTOR UJT P ON N 2N2647 TO-72 Mfr Code 03508, Mfr Part No. 2N2647.
- Add: A2R87, HP Part No. 0684-1811, Description R:FXD COMP 180 OHM 10% 1/4W, Mfr Code 01121, Mfr Part No. CB 1811.
- Change: A5R60, Qty to 2.
- Change: A2Q11, HP Part No. to 1854-0087, Description to TSTR:SI NPN Mfr Code to 80131, Mfr Part No. to 2N3417.
- Change: A2Q4, Qty to 1
- Change: A2C13, A2C14, A2C15, A2C18, A2C19; HP and Mfr Part Nos. to 0160-3007, Description +80-20% to ±20%, Mfr Code to 28480.

Table 8-3. Schematic Diagram Notes,

Add the following symbols to table 8-3.

  A conducting connection to a chassis or frame.

 Earth or safety ground. A direct conducting connection to the earth, or a conducting connection to a structure that has a similar function.

NOTE

Until this manual is revised, this symbol also indicates circuit common on the schematics.

Figure 8-7. Auxiliary A and Auxiliary B Wiring Diagram, Change the wire color codes on J8/J9 as follows:

Pin	Color
A2	(1) BRN
A3	(3) ORN
A4	(4) YEL
A5	(5) GRN
A6	(8) GRA
A7	(7) VIO

Figure 8-13. High Voltage Schematic, Add: R87 180 resistor in parallel with A2L2.

CHANGE 1

NOTE

The BEAM FIND and CALIBRATOR features have been removed from instruments with serial numbers prefixed 1850A and greater. Disregard all manual entries concerning these features.

- Table 1-1. Specifications,
Delete Calibrator and Beam Finder specifications.
- Figure 3-1. Model 141T Controls and Indicators,
Delete references 13 and 14.
- Paragraph 5-9. Beam Finder Performance Test,
Delete paragraph 5-9.
- Paragraph 5-14. Calibrator Performance Test,
Delete paragraph 5-14.
- Paragraph 5-29. Calibrator Adjustment.
Delete paragraph 5-29.
- Performance Test Record,
Delete Beam Finder and Calibrator entries.

- Table 6-2. Replaceable Parts,
Change: A2 (POWER SUPPLY BOARD) HP and Mfr Part Nos. to 00141-66524.
Change: A5 (PULSE CIRCUIT BOARD) HP and Mfr Part Nos. to 00141-66525.
Delete: J4, J5.
Change: MP3 (PANEL: FRONT) HP and Mfr Part Nos. to 00141-60207.
Delete: MP29.
Change: W2 (CABLE: MAIN) HP and Mfr Part Nos. to 00141-61637.
Delete: A2CR19, A2Q12, A2R50, A2R51, A2R52, A2R54, A2R55, A2VR6.
Change: A5CR26, HP Part No. 1901-0036, DIODE-HV RECT 1KV 600MA DO-29, Mfr Code 04713, Mfr Part No. SR 1358-12.
Delete: A5CR27
Change: A5R10, HP Part No. 2100-3253, Qty 2, RESISTOR-TRMR 50K 10% TOP ADJ 1-TRN, Mfr Code 32997, Mfr Part No. 3386P-Y46-503.
Change: A5R14, HP Part No. 2100-3355, Qty 3, RESISTOR-TRMR 100K 10% TOP ADJ 1-TRN, Mfr Code 32997, Mfr Part No. 3386X-Y46-104.
Add: A5R42, HP Part No. 2100-3355, Qty 3, RESISTOR-TRMR 100K 10% TOP ADJ 1-TRN, Mfr Code 32997, Mfr Part No. 3386X-Y46-104.
Add: A5R45, HP Part No. 2100-3253, Qty 2, RESISTOR-TRMR 50K 10% TOP ADJ 1-TRN, Mfr Code 32997, Mfr Part No. 3386P-Y46-503.
Add: A5R63, HP Part No. 2100-3355, Qty 3, RESISTOR-TRMR 100K 10% TOP ADJ 1-TRN, Mfr Code 32997, Mfr Part No. 3386X-Y46-104.
Delete: A5R64.
Change: A5S1, HP Part No. 3101-2350, SWITCH 5-SECTION, Mfr Code 28480, Mfr Part No. 3101-2350.

Figure 8-6. Plug-in Jack Connections,
Change pin connections as follows:

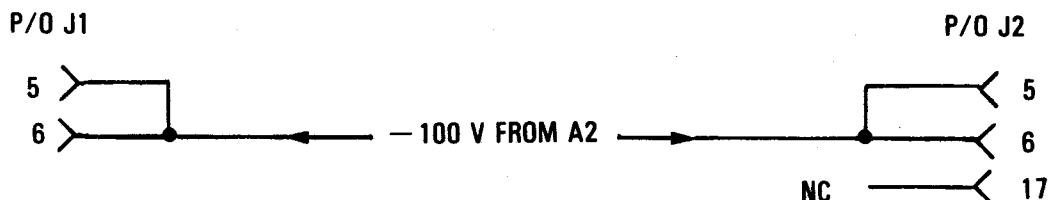

Figure 8-8 and 8-11. Component Identification, Power Supply A2,
Delete the following components:

CR19	R52
Q12	R54
R50	R55
R51	VR6

Figure 8-14. Component Identification, Pulse Circuit A5,

Change figure 8-14 as follows:

Delete: CR27, R64, and S1F

Change: R10A to R10

R10B to R45

R14A to R14

R14B to R42

R14C to R63

Figure 8-16. Schematic 3,

Delete: A5CR27, A5R64 and connection to J2, pin 17.

Change: A5R10A to A5R10

Change: A5R10B to A5R45

Change: A5R14A to A5R14

Change: A5R14B to A5R42

Change: A5R14C to A5R63

Delete: S1F and associated circuitry.

CHANGE 2

Table 6-2. Replaceable Parts,

Change: A2, HP and Mfr Part Nos. to 00141-66528.

Delete: A2R38.

Change: A2R48, HP Part No. to 0698-3558, Qty to 1, Description to 4.02K OHM, Mfr Code to 24546 and Part No. to C4-1/8-TO-4021-F.

Change: A2R8, Qty to 1.

Change: A2R12, HP and Mfr Part Nos. to 0757-0352, Qty to 1, Description to 150K OHM.

Change: A5R26, Qty to 1.

Change: A2R10, HP and Mfr Part Nos. to 0757-0309, Qty to 1, Description to 61.9K OHM.

Change: A2R31, Qty to 1.

Change: A2R24, HP Part No. to 0757-0339, Qty to 1, Description to 3.01K 1/4W, Mfr Code to 24546 and Part No. to C5-1/4-TO-3011-F.

Change: A2R34, HP Part No. to 0698-3155, Qty to 2, Description to 4.64K OHM, Mfr Code to 24546 and Part No. to C4-1/8-TO-4641-F.

Change: A5R8, Delete Qty.

Change: A2R26, HP and Mfr Part Nos. to 0698-8140, Qty to 1, Description to 15K OHM, 2%.

Change: A2R39, HP and Mfr Part Nos. to 0757-0060, Qty to 1, Description to 24.3K OHM.

Change: A2R43, HP and Mfr Part Nos. to 0757-0848, Qty to 1, Description to 30.1K OHM.

Change: A2R47, HP and Mfr Part Nos. to 2100-0567, Delete Qty, Description to R-TRMR COMP 2K OHM 10% TOP-ADJ 1 TRN.

Change: A2R11, HP and Mfr Part Nos. to 2100-3210, Description to R-TRMR COMP 10K OHM 10% TOP-ADJ 1-TRN.

Add: A2R25, HP and Mfr Part Nos. are 2100-0567, Qty is 3, Description is R-TRMR COMP 2K OHM 10% TOP-ADJ 1-TRN.

Add: A2R37, HP and Mfr Part Nos. are 2100-0567, Description is R-TRMR COMP 2K OHM 10% TOP-ADJ 1-TRN.

Figure 8-8 and 8-11. Component Identification, Power Supply A2,

Delete the following components:

R47B and R38

Change the reference designator of the following components:

R11A to R11

R11B to R25

R11C to R37

R47A to R47

Figure 8-10. Schematic 1,

Delete: R47B and R38 (from diagram and table)

Change the value of the following components:

R48 to 4020

R12 to 150K

R10 to 61.9K

R24 to 3010K

R34 to 4640

R26 to 15K

R39 to 24.3K

R43 to 30.1K

Change the reference designator (on diagram and table) and value of the following components:

R47A to R47 (2000)

R11A to R11 (10K)

R11B to R25 (2000)

R11C to R37 (2000)

Change the following reference designators:

Paragraph 4-20 (page 4-2): A2R11B to A2R25

Paragraph 4-21 (page 4-2): A2R11C to A2R37

Paragraph 4-23 (page 4-2): A2R11A to A2R11

Table 5-2 (page 5-4) and Figure 5-1 (page 5-7/5-8):

A2R11B to A2R25

A2R11C to A2R37

A2R11A to A2R11

A2R47A to A2R47

Delete: CAL ADJ R2R47B

▲ CHANGE 3

Table 6-2. Replaceable Parts (Section VI),

Change: A1C1, Qty to 7.

Change: A2, HP and Mfr Part Nos. to 00141-66532.

Change: A2C1, Qty to 5.

Change: A2C3, HP and Mfr Part Nos. to 0140-0176, Qty to 2, Description to C:FXD MY 100PF \pm 1% 300 VDC, Mfr Code to 28480.

Change: A2C4, HP Part No. to 0180-0269, Qty to 1, Description to C:FXD AL 1UF+50-10% 15 VDC, Mfr Code to 56289, Mfr Part No. to 30D105G150BA2.

Change: A2C5, HP and Mfr Part Nos. to 0140-0176, Description to C:FXD MY 100PF \pm 1% 300 VDC, Mfr. Code to 28484.

Change: A2C7, Qty to 1.

Change: A2Q4, HP and Mfr Part Nos. to 1854-0071, Qty to 20, Description to TSTR:SI NPN (SELECTED FROM 2N3704).

Change: A2Q5, delete 20 from Qty.

Change: A2Q11, Qty to 1.

Change: A2R20, HP and Mfr Part Nos. to 0757-0060, Description to R:FXD FLM 24.3K 1% 1/2W.

Change: A2R6, Qty to 3.

Change: A2R21, HP and Mfr Part Nos. to 0757-0060, Description to R:FXD FLM 24.3K 1% 1/2W, Mfr Code to 28480.

Change: A2R22, HP Part No. to 0757-0435, Description to R:FXD FLM 3.92K 1% 1/2W, Mfr Code to 24546, Mfr Part No. to C4-1/8-TO-3921-F.

Change: A2R23, HP and Mfr Part Nos. to 0757-0044, delete 3 from Qty, Description to R:FXD FLM 33.2K 1% 1/2W.

Change: A2R24, HP Part No. to 0757-0435, Qty to 1, Description to R:FXD FLM 3.92K 1% a/2W, Mfr Code to 24546, Mfr Part No. to C4-1/8-TO-3921-F.

Add: A2R25, HP and Mfr Part Nos. 2100-3211, Qty 1, Description R:TRMR COMP 1K 10% TOP-ADJ 1 TRN, Mfr Code 28480.

NOTE

R11B changed to R25 per Change 2.

Change: A2R26, HP Part No. to 0757-0767, Qty to 1, Description to R:FXD FLM 43.2K 1% 1/4W, Mfr Code to 24546, Mfr Part No. to C4-1/8-TO-3921-F.

Change: A2R30, Qty to 1.

Change: A2R33, Qty to 2.

Change: A2R34, Qty to 1.

Change: A2R36, Qty to 1.

Change: A2R39, Qty to 2.

Change: A2R74, HP and Mfr Part Nos. to 0699-0167, Qty to 1, Description to R:FXD COMP 20 MEGOHM 5% 1W.

Delete: A2R75 thru A2R81.

Delete: A2V1.

Add: VR7, HP Part No. 1902-0787, Qty 1, Description DIODE:BREAKDOWN 9V 5%, Mfr Code 04713, Mfr Part No. 1N938.

Change: V1, HP and Mfr Part Nos. to 5083-2511.

Add: MP57, HP and Mfr Part Nos. to 1000-0597, Qty 1, Description to FILTER-RFI, Mfr Code to 28480.

Change: MP97, HP and Mfr Part Nos. to 0141-40601.

Paragraph 4-20 (page 4-2),

Change: A2V1 to A2R20/R21.

Paragraphs 5-25 to 5-28 (page 5-3 to 5-5),

Refer to Figure 1 of this document for location of power supply, intensity, and geometry adjustments.

Figure 8-8. Component Identification, Power Supply A2 (page 8-14),

Replace with Figure 1 of this document.

Figure 8-10. Low Voltage Schematic (page 8-15),

Replace with Figure 2 of this document.

Figure 8-11. Component Identification Power Supply A2 (page 8-16),

Replace R74-R81 on Grid with R74.

Replace R74-R81 in Loc chart with R74 G-2.

Figure 8-13. High Voltage Schematic (page 8-17),

Delete R75-R81 from diagram and Parts Chart.

Change value of R74 on diagram to 20M.

FREE DISTRIBUTION VK5ZLR

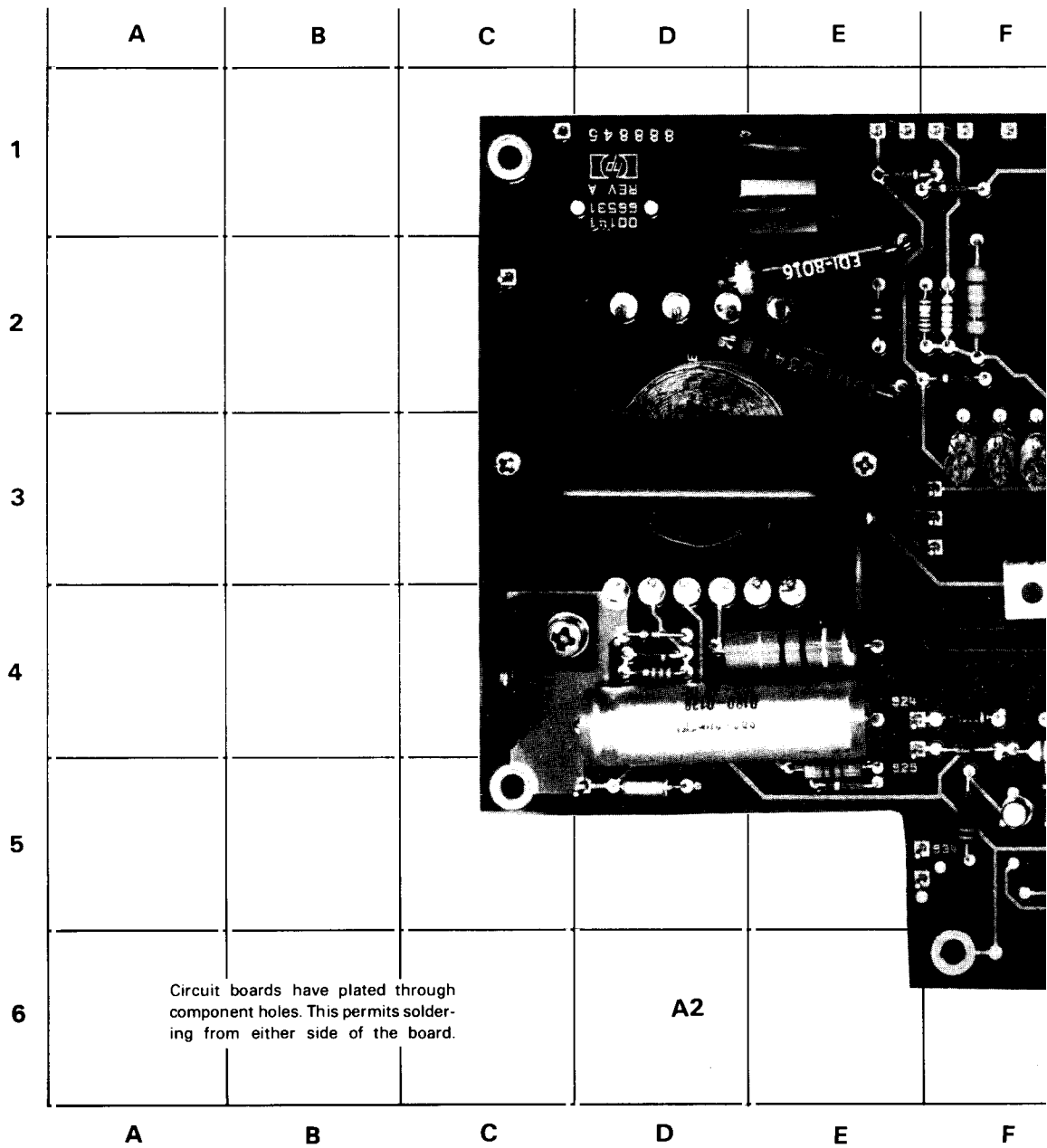

REF DESIG	GRID LOC	REF DESIG	GRID LOC	REF DESIG	GRID LOC	REF DESIG
C1	K-2	CR3	K-3	CR17	I-4	Q5
C2	K-5	CR4	J-3	CR18	J-4	Q6
C3	J-3	CR5	J-1	F1	K-5	Q7
C4	J-2	CR8	I-1	F2	K-5	Q8
C5	J-2	CR10	J-3	F3	I-5	Q9
C6	I-2	CR11	J-3	F4	I-5	Q10
C7	I-4	CR13	I-3	Q1	K-3	Q11
C8	J-5	CR14	I-3	Q2	K-3	R1
C9	I-3	CR15	I-2	Q3	I-2	R2
C20	I-4	CR16	J-5	Q4	J-3	R3
CR2	K-2					

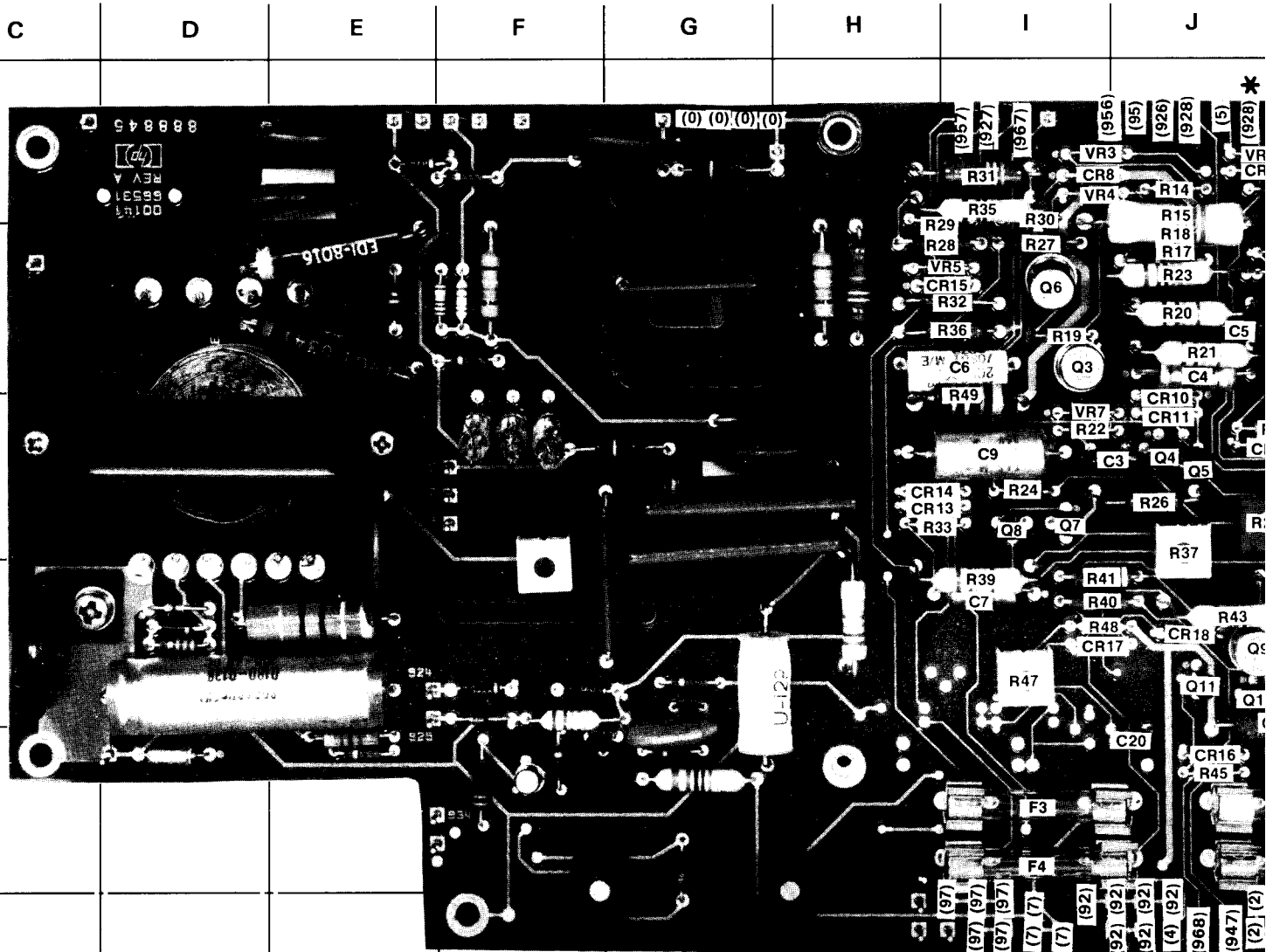

plated through
is permits solder-
de of the board.

A2

C D E F G H I J

REF DESIG	GRID LOC	REF DESIG	GRID LOC	REF DESIG	GRID LOC	REF DESIG	GRID LOC	REF DESIG	GRID LOC	REF DESIG	GRID LOC	REF DESIG	GRID LOC	REF DESIG	GRID LOC
C1	K-2	CR3	K-3	CR17	I-4	Q5	J-3	R4	K-1	R14	J-1	R24	I-3	R34	K-3
C2	K-5	CR4	J-3	CR18	J-4	Q6	I-2	R5	J-1	R15	J-2	R25	J-3	R35	I-1
C3	J-3	CR5	J-1	F1	K-5	Q7	I-3	R6	K-2	R16	K-2	R26	J-3	R36	I-2
C4	J-2	CR8	I-1	F2	K-5	Q8	I-3	R7	K-2	R17	J-2	R27	I-2	R37	J-4
C5	J-2	CR10	J-3	F3	I-5	Q9	J-4	R8	J-3	R18	J-2	R28	I-2	R39	I-4
C6	I-2	CR11	J-3	F4	I-5	Q10	J-4	R9	J-2	R19	I-2	R29	I-2	R40	I-4
C7	I-4	CR13	I-3	Q1	K-3	Q11	J-4	R10	K-4	R20	J-2	R30	I-2	R41	I-4
C8	J-5	CR14	I-3	Q2	K-3	R1	K-1	R11	K-3	R21	J-2	R31	I-1	R43	J-4
C9	I-3	CR15	I-2	Q3	I-2	R2	K-2	R12	K-4	R22	J-3	R32	I-2	R44	K-4
C20	I-4	CR16	J-5	Q4	J-3	R3	K-4	R13	K-1	R23	J-2	R33	I-3	R45	J-5
CR2	K-2														

Figure 1. Component Identifi

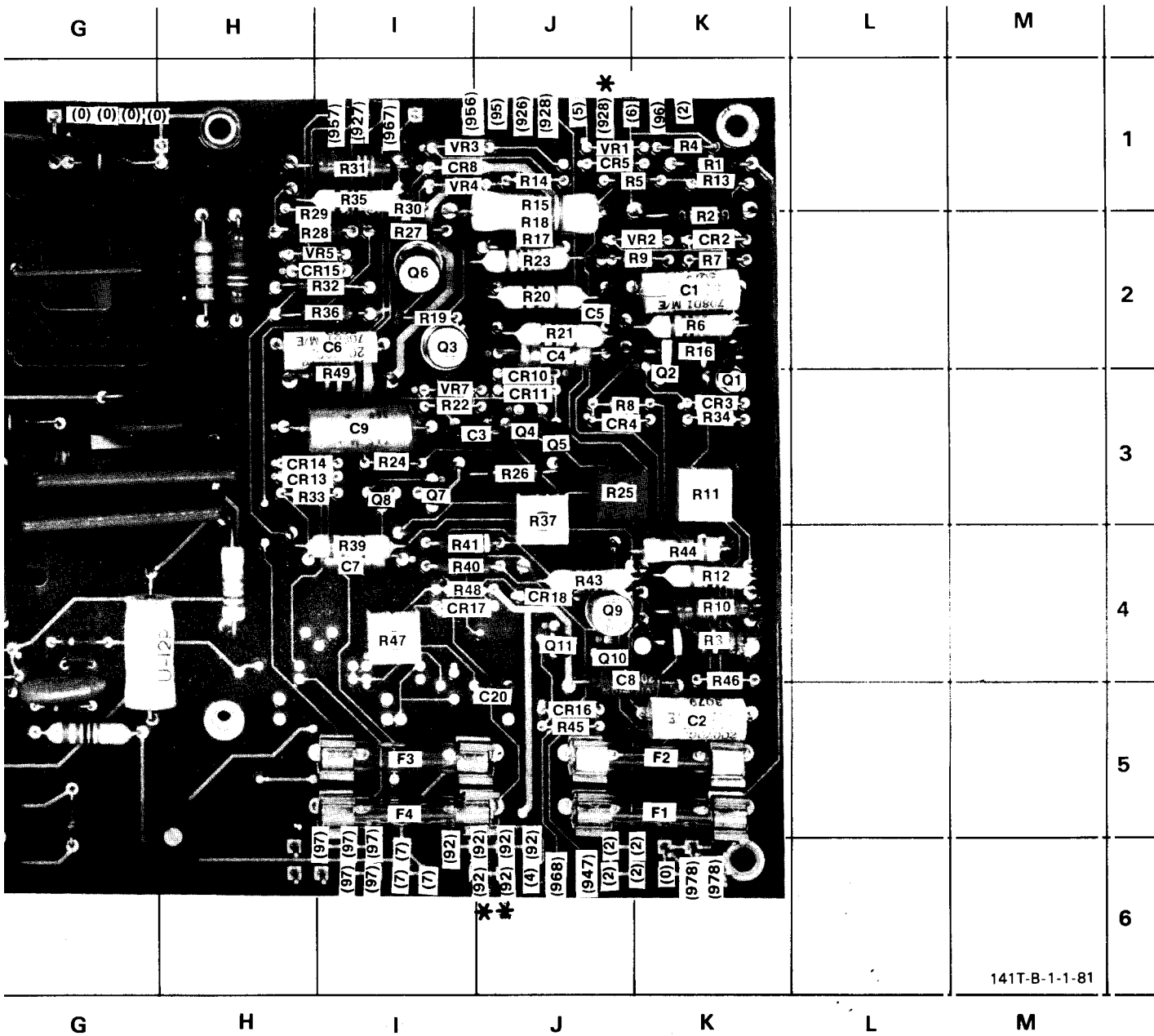

REF DESIG	GRID LOC	REF DESIG	GRID LOC	REF DESIG	GRID LOC	REF DESIG	GRID LOC	REF DESIG	GRID LOC
R4	K-1	R14	J-1	R24	I-3	R34	K-3	R46	K-4
R5	J-1	R15	J-2	R25	J-3	R35	I-1	R47	I-4
R6	K-2	R16	K-2	R26	J-3	R36	I-2	R48	I-4
R7	K-2	R17	J-2	R27	I-2	R37	J-4	R49	I-3
R8	J-3	R18	J-2	R28	I-2	R39	I-4	VR1	J-1
R9	J-2	R19	I-2	R29	I-2	R40	I-4	VR2	K-2
R10	K-4	R20	J-2	R30	I-2	R41	I-4	VR3	I-1
R11	K-3	R21	J-2	R31	I-1	R43	J-4	VR4	I-1
R12	K-4	R22	J-3	R32	I-2	R44	K-4	VR5	I-2
R13	K-1	R23	J-2	R33	I-3	R45	J-5	VR7	I-3

Figure 1. Component Identification, Power Supply A2

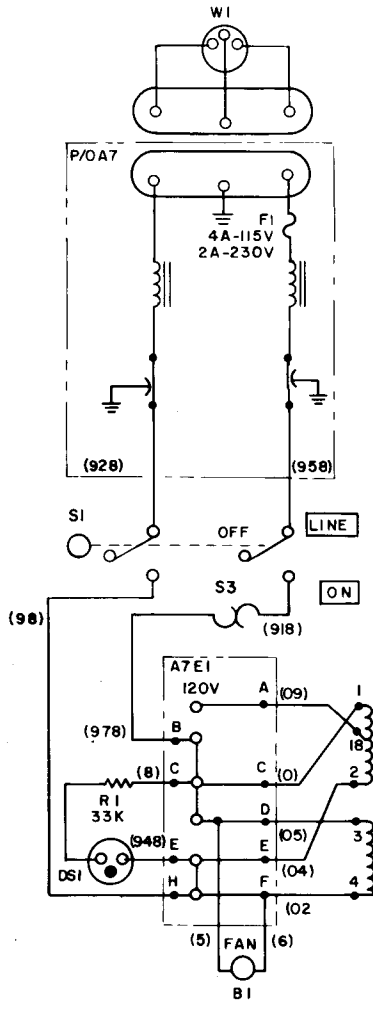

REFERENCE DESIGNATIONS

CHASSIS	A1	A2
B1	C1-C3	C1-C9
C1-C6	CR1-CR12	CR2-CR5, CR8, CR10, CR11, CR13-CR19
DS1		
P/OJ1, P/OJ2	A7	Q1-Q11
J7		R1, R41, R43-R52
Q1-Q4	E1	R54, R55
R1-R4, R11	F1	V1
S1-S3		VR1-VR5, VR7
T1		
W1		

DELETED :

F1, J3, S2, J6, A2CR1, A2CR6, A2CR7, A2CR9, A2CR12, A2CR20, A2VR6, A2012, A2R42, A2R50-R55

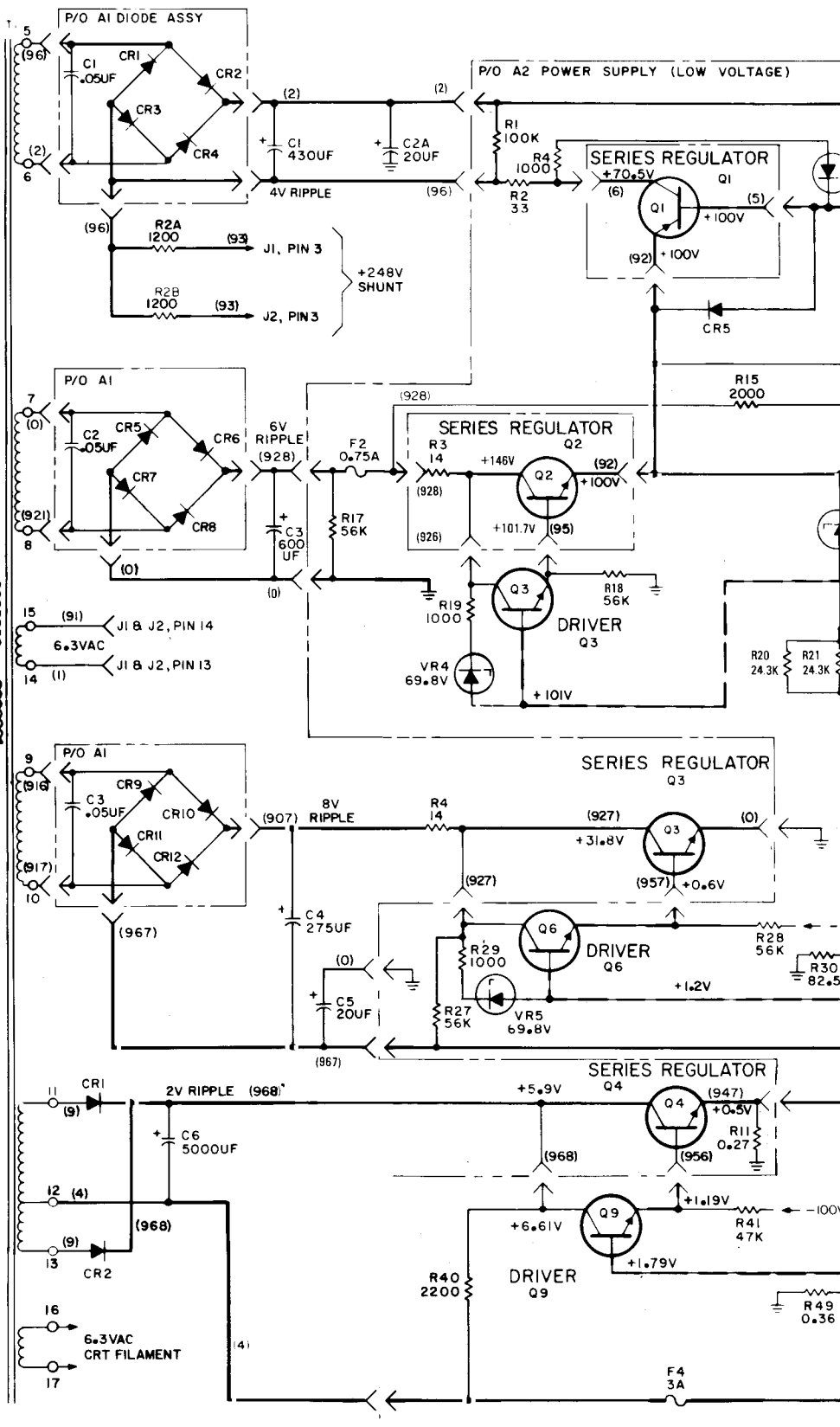

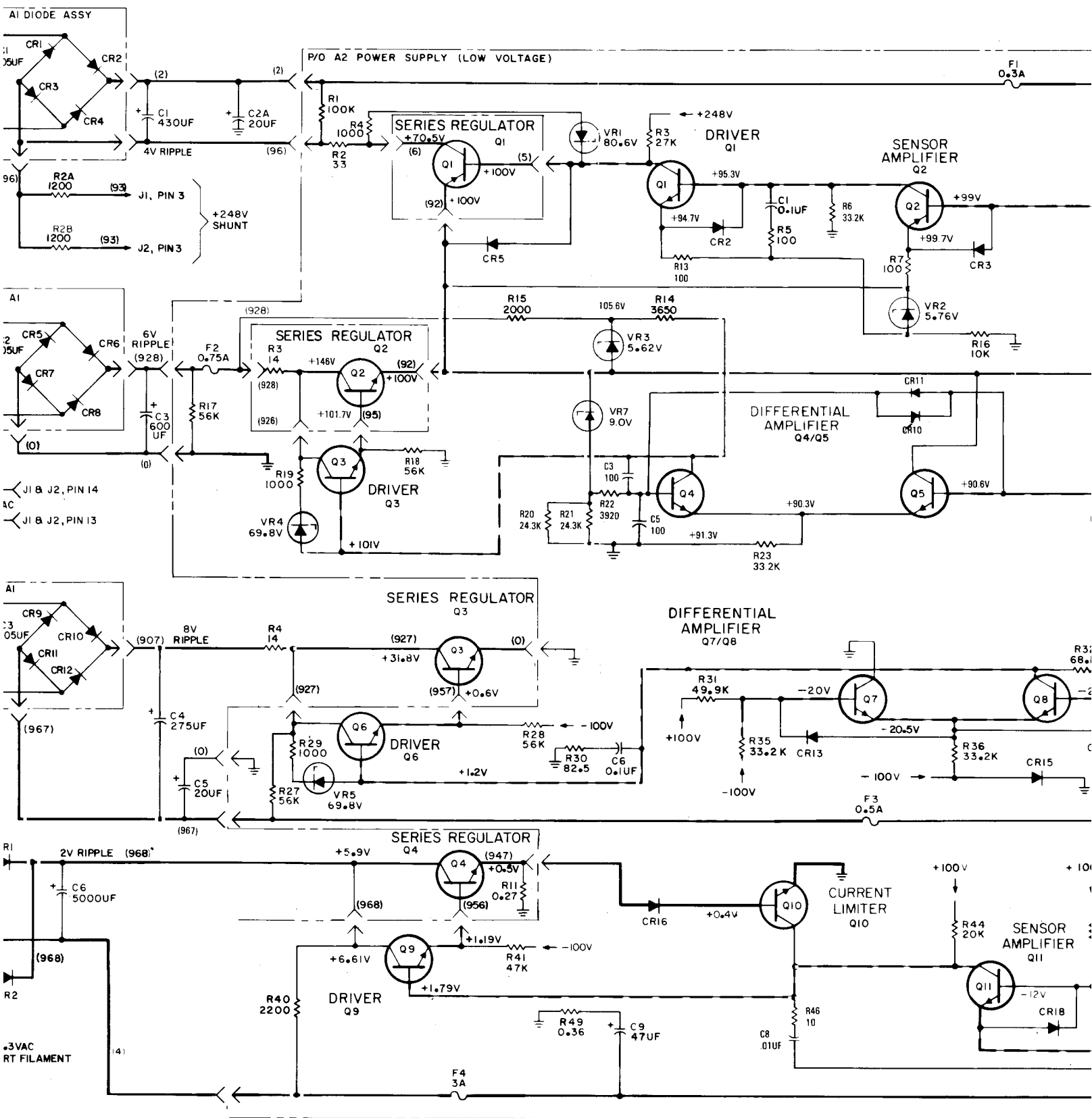

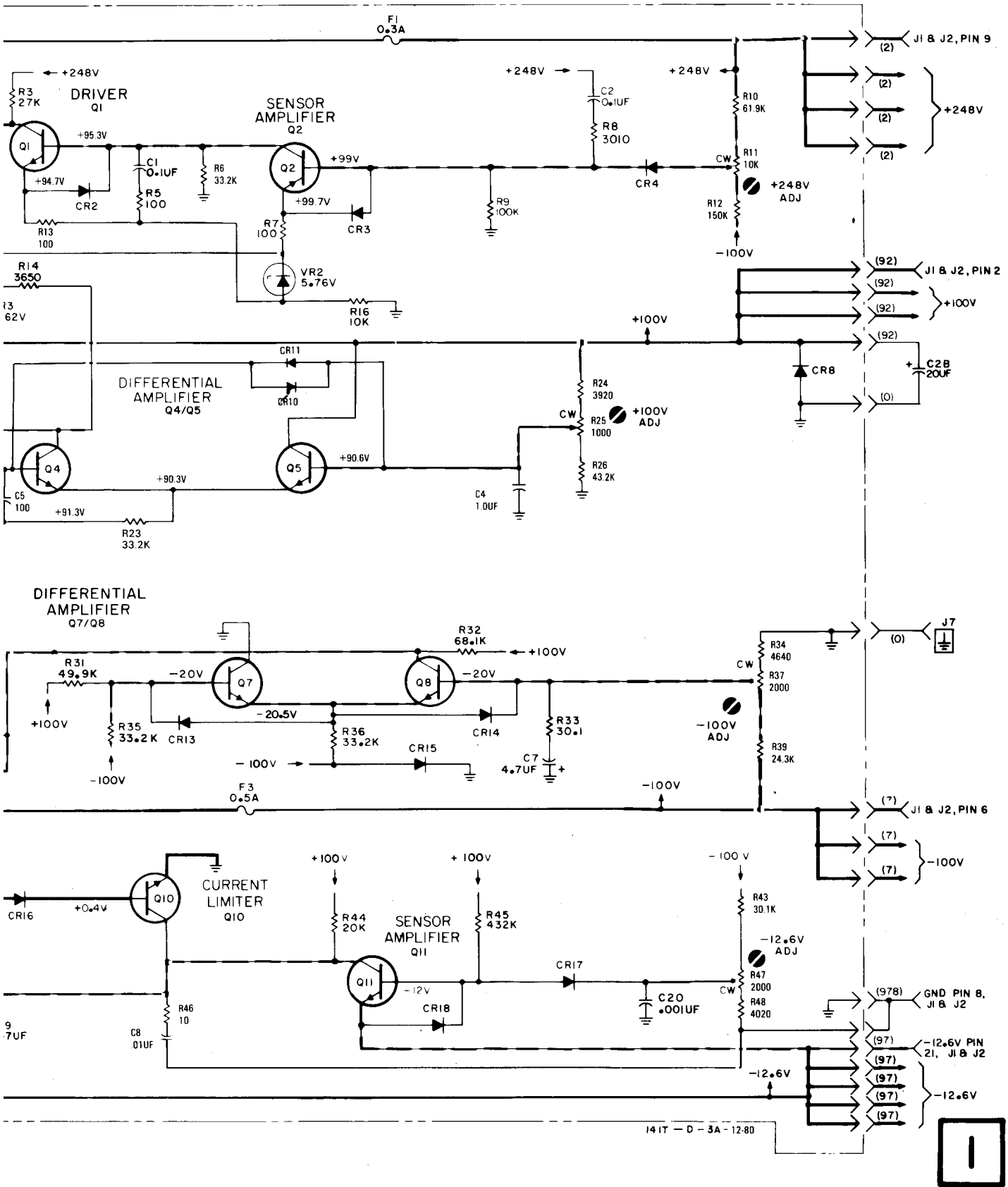

Figure 2.
Low Voltage Schematic
8

K4XL's **BAMA**

This manual is provided **FREE OF CHARGE** from the “BoatAnchor Manual Archive” as a service to the Boatanchor community.

It was uploaded by someone who wanted to help you repair and maintain your equipment.

If you paid anyone other than BAMA for this manual, you paid someone who is making a profit from the free labor of others without asking their permission.

You may pass on copies of this manual to anyone who needs it. But do it without charge.

Thousands of files are available without charge from BAMA. Visit us at <http://bama.sbc.edu>